

TERMINATION STEPS

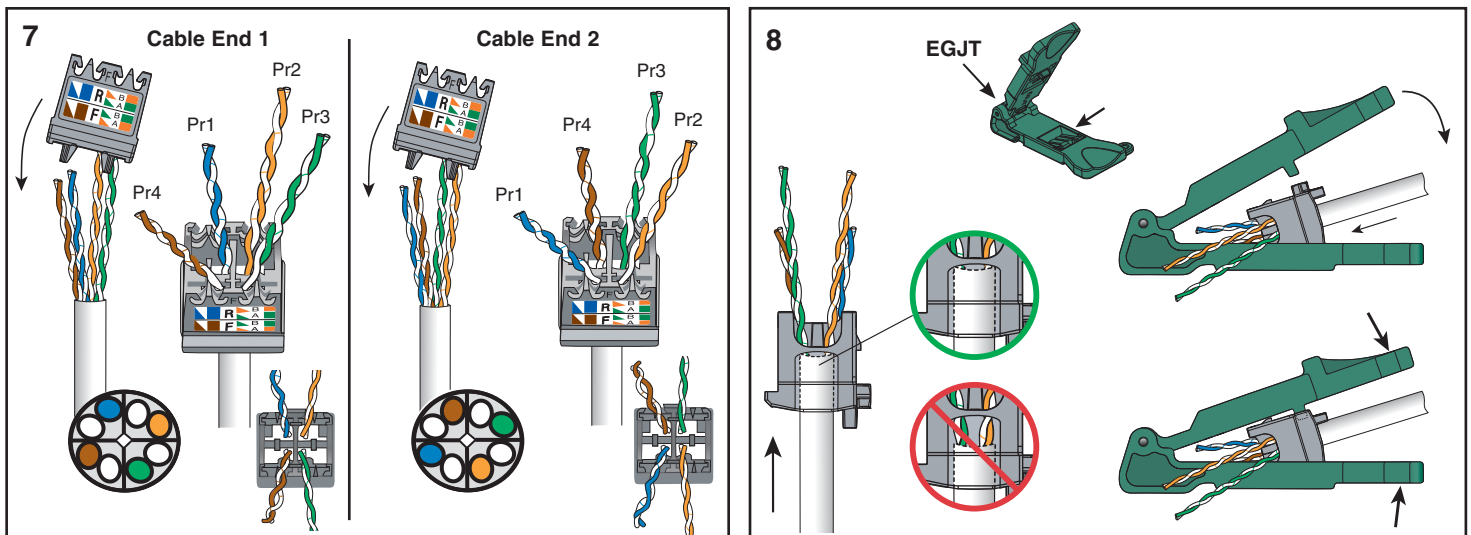
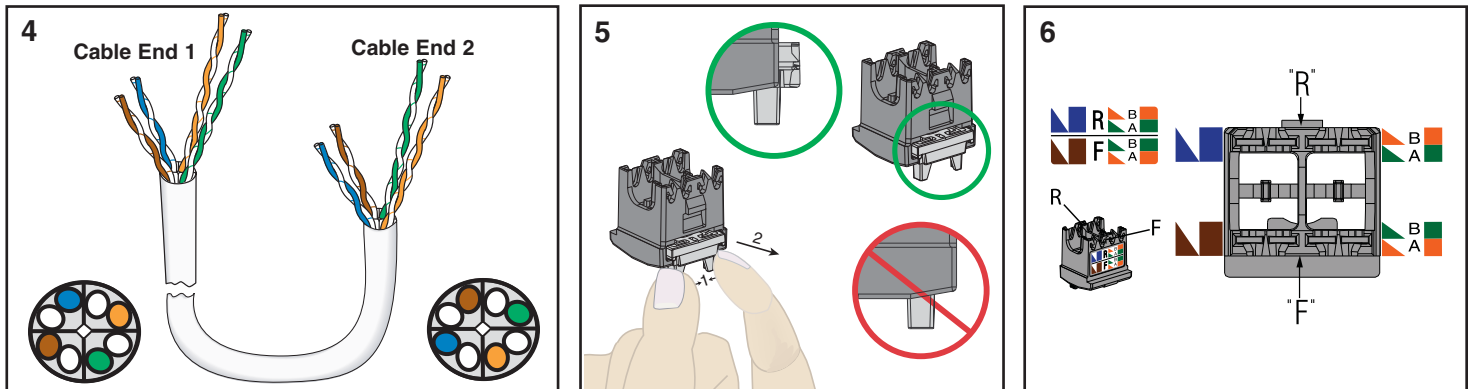
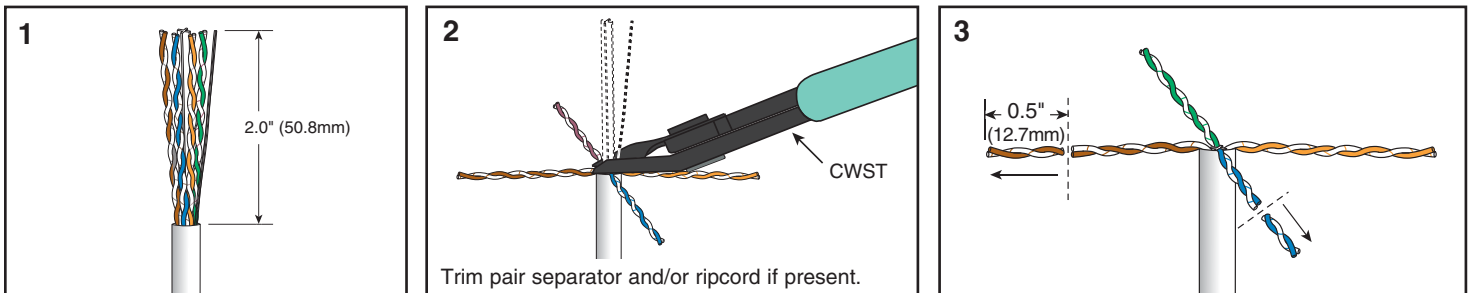

Note: For bulk packaged TG Style Jack Modules add -24 to end of part number.

** Denotes color.

9

T568B

Cable End 1

Cable End 2

T568A

Cable End 1

Cable End 2

See note 4.

10

11

12

13

REMOVAL STEPS

1

2

3

- Notes:**
- For specified performance, follow ANSI/NECA/BICSI-568-2006 installation guidelines.
 - Jack Modules can terminate 22-26 AWG solid or stranded IWC data cable with 0.062 (1.57 mm) maximum insulated conductor outside diameter.
 - Jack Modules may be re-terminated a minimum of 20 times.
 - On cable end 2 for A & B wiring and cable end 1 of A wiring, wrap the designated pairs around the proper center dividing post (A or B) and terminate in the proper location.
 - For technical and performance information, consult Panduit Technical Support.

- As with all Communication Components, the following statements apply:**
- Never install communications wiring during a lightning storm.
 - Never install communications wiring in wet locations unless the jack is specifically designed for use in wet locations.
 - Never touch uninsulated communications wiring or terminals unless the communication line has been disconnected at the network interface.
 - Use caution when installing or modifying communication wiring.

<p>For Instructions in Local Languages and Technical Support:</p> <p>http://www.panduit.com/resources/install_maintain.asp</p>	<p>www.panduit.com</p>	<p>E-mail: techsupport@panduit.com</p> <p>Phone: 866-405-6654</p>
---	---	---